

EVOLUTION™
STEEL DECK FRAMING



THE NEXT EVOLUTION IN DECKS

PRODUCT CATALOG





CONTENTS

- 1 Our Story**
- 3 Wood to Steel**
- 4 Why Evolution?**
- 9 Peace of Mind & Sustainability**
- 10 System Overview**
- 11 System Components**
 - 12 Joist**
 - 13 S-Ledger**
 - 14 Beam & Double Beam**
 - 15 Rim Joist**
 - 16 Post & Post Brackets**
 - 17 Brackets**
 - 19 Blocking**
- 20 Product Guide**
- 30 Steel Stair System**
- 32 Steel Stair System Overview**
- 33 Steel Stair System Components**
- 35 Steel Stair Product Guide**
- 38 Fortress Preferred Program**

EVOLUTION™
STEEL DECK FRAMING

Patent Pending

THE BIRTH OF EVOLUTION STEEL FRAMING

A few years ago, a Colorado deck builder approached Fortress Building Products and, knowing our capabilities for steel building materials, recommended we create a metal deck framing system to fill a void in the North American market. We investigated and found that places like Australia and South Africa had already moved to metal framing systems, while most North American builders still relied on wood products. Fortress met with deck builders, and it quickly became clear the market needs a steel system that is affordable, looks and assembles like wood, and is easy to install. To answer these requests, we introduced Evolution by Fortress Framing, a steel system designed by deck builders, for deck builders.



TRUST IN FORTRESS

In 2002, Fortress opened its doors and quickly became a market leader in alternative fence and railing solutions that are durable, low maintenance, high strength, and easy to install. Through the years, Fortress has expanded its line-up and now specializes in alternative outdoor building products, including railings, fence, pergola, and bamboo-based composite decking.



EVOLUTION

**A SMARTER STEEL FRAMING SYSTEM
DESIGNED BY DECK BUILDERS,
FOR DECK BUILDERS.**

BUILDING MATERIALS, THEN AND NOW

We've relied on wood construction for centuries – for bridges, oil derricks, and even warships. Once we learned to work with steel, however, builders abandoned many wood structures in favor of durable steel. Today, leading deck builders around the world are choosing sustainable steel framing over old-fashioned wood framing.



WOOD VS STEEL COMPARISON

	WOOD FRAMING	EVOLUTION™ STEEL DECK FRAMING
EASY TO INSTALL	✓	✓
STRAIGHT, UNIFORM PIECES	✗	✓
BUILD BEYOND LIMITATIONS	✗	✓
COMPATIBILITY	✓	✓
LONG-LIFE WARRANTY	✗	✓
A SMART INVESTMENT	✗	✓
AESTHETICALLY BEAUTIFUL	✗	✓
FIRE- AND INSECT-RESISANT	✗	✓
SUSTAINABLE	✗	✓



WHY EVOLUTION?



EASY TO INSTALL

Designed and engineered to look and install like wood. If you know how to frame with wood, you can frame with Evolution.



STRAIGHT, UNIFORM PIECES

Light-gauge steel provides a perfectly flat surface without crowning, warping, or cracking over the life of your deck. Builds flat, stays flat!



BUILD BEYOND LIMITATIONS

Our steel deck framing has been engineered to provide greater spans between supports, resulting in fewer columns for less obstructed views.



COMPATIBILITY

Evolution steel deck framing is compatible with any type or brand of decking, including composite, PVC, aluminum, tile, wood, and tropical hardwoods.



IT'S WHAT YOU DON'T SEE THAT COUNTS

LIFETIME COST OF YOUR DECK

Half the cost, none of the worry.

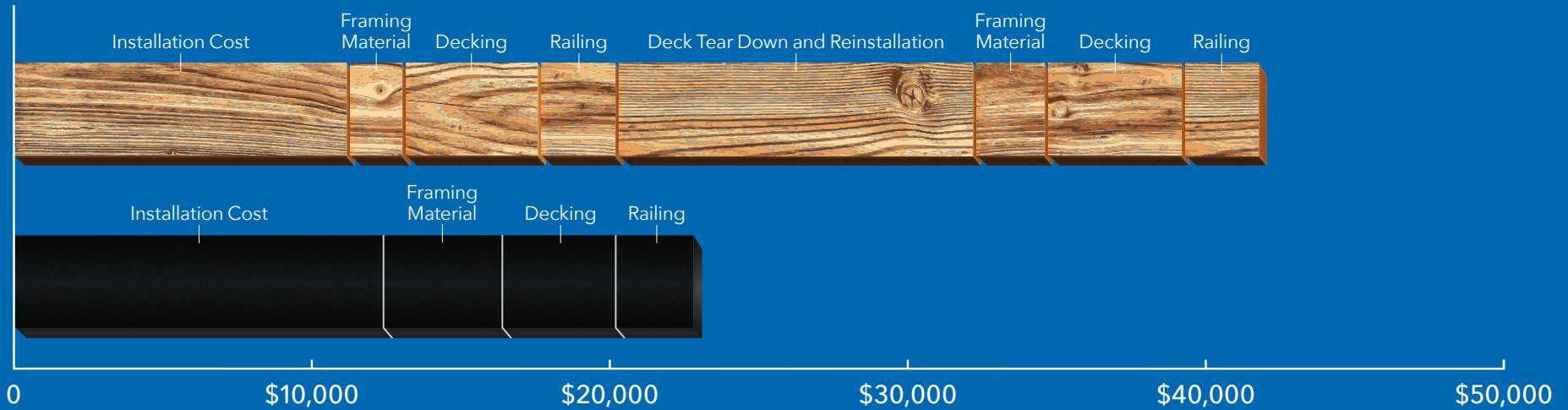

Estimated professionally installed cost for a 20'x20' deck. Based on company market research. Cost for decking and railing are based on wood alternative products.



LONG-LIFE WARRANTY

We believe your framing should last at least as long as the decking it supports. Evolution carries a 25-year limited manufacturer warranty.



A SMART INVESTMENT

Like all Fortress products, Evolution by Fortress Framing is designed on our core concepts of low-maintenance, durability, ease of installation, and safety.



AESTHETICALLY BEAUTIFUL

The premium Black Sand powder coat provides an aesthetically pleasing look that virtually disappears when you're above or below your deck. Now you can build with or without fascia.



FIRE- AND INSECT-RESISTANT

Evolution steel deck framing is noncombustible material, resistant to fire and invulnerable to rotting, warping, splitting, and pesky insect damage.



A SOLID FOUNDATION



ENVIRONMENTALLY SOUND



INSECTICIDE-FREE

Wood boards are often soaked with insecticide and fungicide. Because steel doesn't attract bugs and microorganisms, it doesn't require this type of treatment.



SUSTAINABLE

Steel is recycled and recyclable, making it more sustainable than wood. Learn more on page 9.

GREAT FOR THE PLANET...

The environment will thank you for choosing steel. While wood is renewable, steel is sustainable. We'll tell you why.

90%

Of all steel is recycled, while 70% of wood is single use.



Recycling steel requires less energy than it originally took to make it.



Recycling steel does not degrade its quality, so it can be recycled over and over.

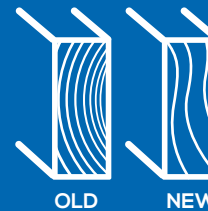

Old growth lumber provided a stronger, denser product that is not sustained in the fast growth lumber of today.

GREAT FOR BUILDERS...

Evolution was designed to be installed like wood, without the difficulty and confusion of typical steel profiles. Evolution consists of a Ledger, Joists, Beams, Posts, and Blocking, making installation quick and easy!

PARTS SHOWN

1. S-Ledger (pre-spaced 12" & 16" O.C.)
2. Ledger Bracket
3. Joist (2"x6")
4. F50 Bracket
5. Strap (mid-span blocking)
6. Beam (2"x11")
7. Beam Cap
8. Post to Beam Bracket
9. Post (3½"x3½"x10")
10. Blocking (12" & 16" O.C.)
11. Post to Pier Bracket
12. Single Hanger Brackets
13. Rim Joist (pre-spaced 12" & 16" O.C.)

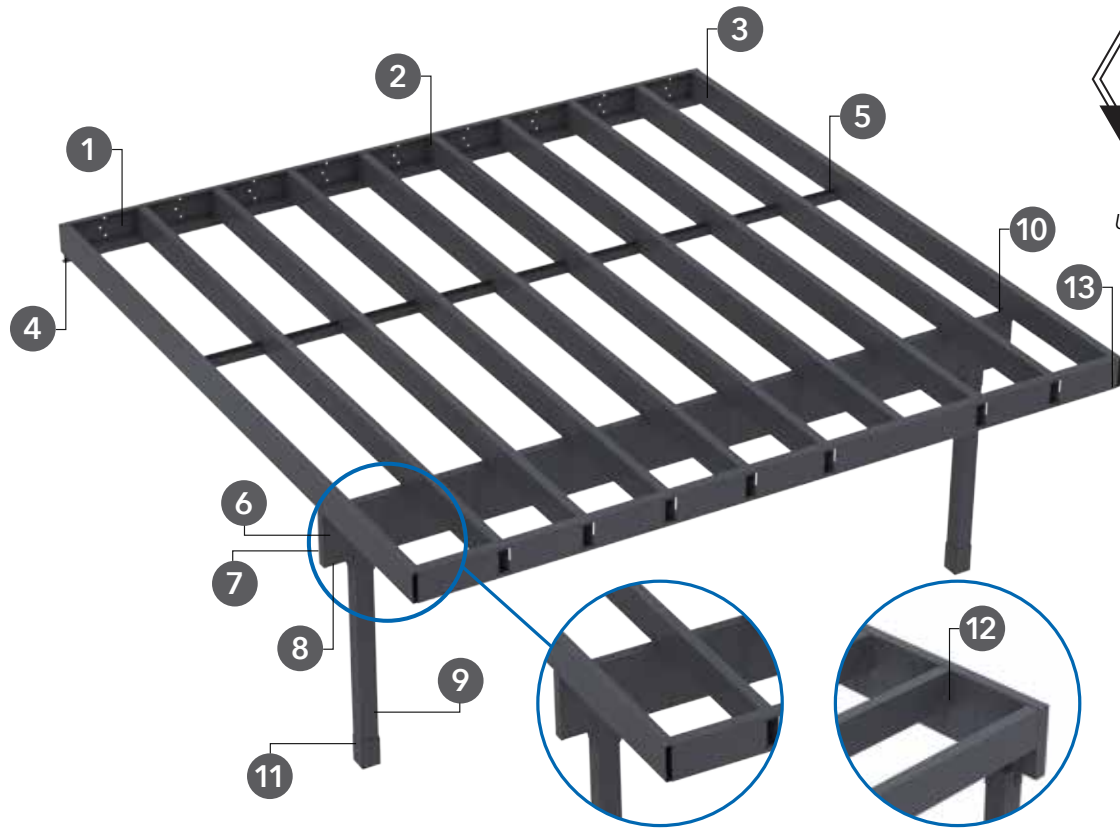

Patent #
US10100516B2

Example of flush beam application

PARTS NOT SHOWN... but available to cover virtually all needs/applications.

14. Double Beam Track
15. Double Hanger Bracket
16. Double Beam to Post Bracket

17. Joist Cap
18. Curved Rim Joist
19. Rim Joist Bracket

20. 45° Bracket
21. F10 Bracket
22. Self Drilling Screw



SYSTEM COMPONENTS

**BUILD SAFE DECKS WITH LESS LABOR.
OUR INTERLOCKING JOIST AND LEDGER
SYSTEM PIECES FIT TOGETHER EASILY.**

JOIST

16 Gauge

Galvanized and powder coated with Black Sand.
Lengths available:
12' | 14' | 16' | 18' | 20'

Joist Cap

Galvanized and powder coated with Black Sand.

18 Gauge

Galvanized.
Lengths available:
12' | 14' | 16' | 18' | 20'

Evolution's Joists are a familiar shape that install quickly and easily with minimal fasteners. The steel joists will hold their shape, providing a perfectly flat deck surface that will not sag or warp over the life of your deck.

16 Gauge Joist



18 Gauge Joist



Joist Cap

Covers open joist to provide clean, finished look and deter pests and animals

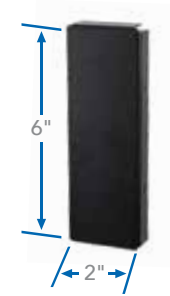

S-LEDGER

12" O.C.

Galvanized and powder coated with Black Sand. Lengths available: 12' | 20'

16" O.C.

Galvanized and powder coated with Black Sand. Lengths available: 12' | 20'

Blank

Galvanized and powder coated with Black Sand. Lengths available: 12' | 20'

Ledger Bracket

Galvanized and powder coated with Black Sand.

Evolution's S-Ledger is an engineered interlocking design with the Ledger Bracket that eliminates the need for excessive fasteners and drastically speeds up installation. The "S" shape provides a sturdy, safe deck connection that will offer peace of mind for decades. The S-Ledger is available with pre-punched, standard spacing options that simplify deck construction.

12" O.C. S-Ledger

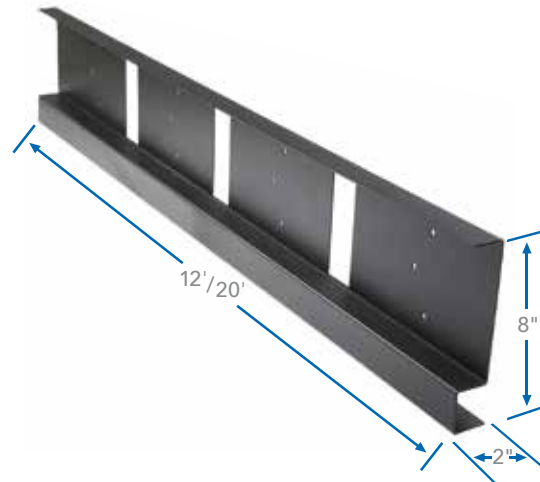

16" O.C. S-Ledger

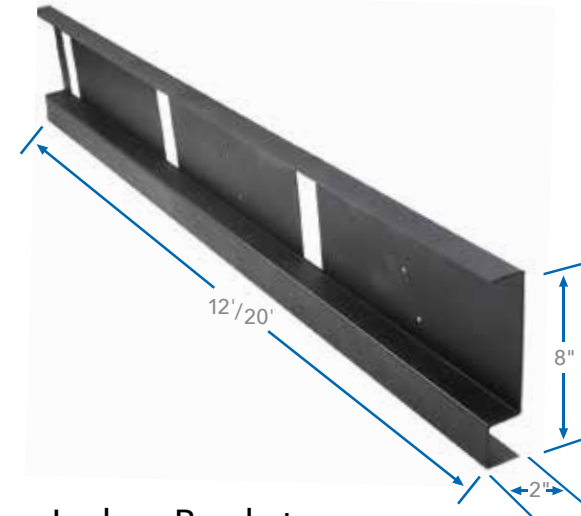

Blank S-Ledger

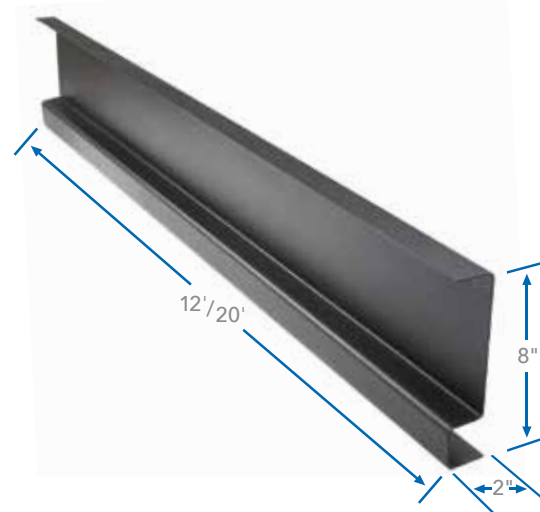

Ledger Bracket

Used with the S-Ledger and joist or fastened to a flush beam

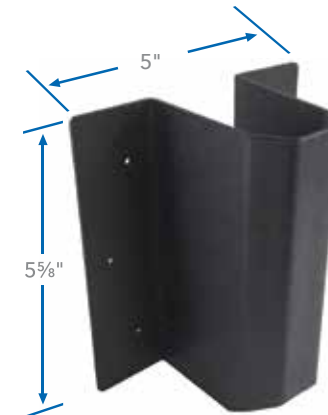

BEAM + DOUBLE BEAM TRACK

Beam

Galvanized and powder coated with Black Sand.
Lengths available:
8' | 12' | 16' | 20'

Beam Cap

Galvanized and powder coated with Black Sand.

Double Beam Track

Galvanized and powder coated with Black Sand.
Lengths available:
4'
Sold in pairs

Evolution's Beam has been engineered to achieve longer spans between supports, eliminating excessive posts and obstructed views.

Beam



Beam Cap

Covers open beams to provide clean, finished look and deter pests and animals



Double Beam Track

Used to connect two beams to create a double beam (attaches to top and bottom of double beam)

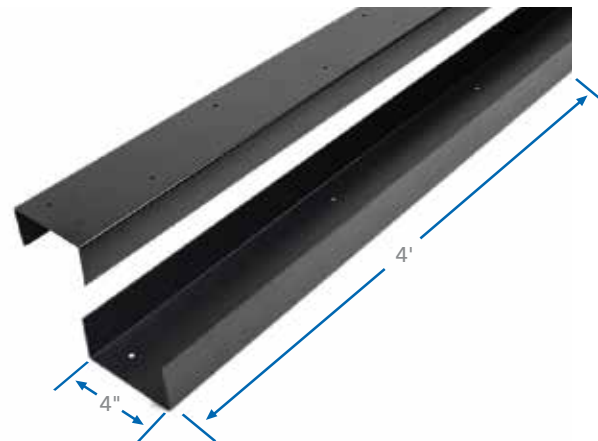

RIM JOIST

12" O.C.

Galvanized and powder coated with Black Sand. Lengths available: 8'

16" O.C.

Galvanized and powder coated with Black Sand. Lengths available: 8'

Blank

Galvanized and powder coated with Black Sand. Lengths available: 8'

Curved

Galvanized and powder coated with Black Sand. Lengths available: 8'

Evolution's Rim Joist incorporates the same pre-punched and non-punched system as the S-Ledger for consistent, quicker installation without the hassle. Evolution's Rim Joists provide a solution for any installation application, including an option for curved decks. The Rim Joist attaches to the Joist with minimal fasteners and provides a perfectly flat surface to attach trim or fascia.

12" O.C. Rim Joist

For use with fascia only

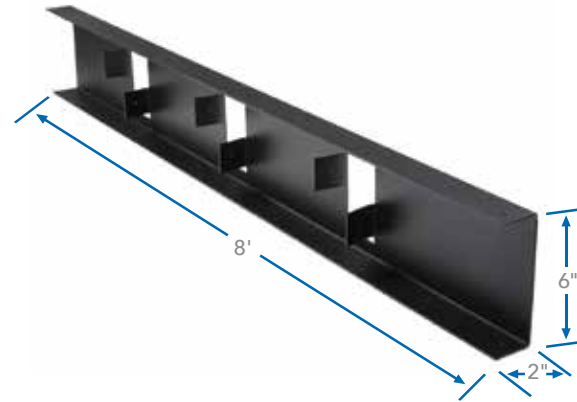

16" O.C. Rim Joist

For use with fascia only

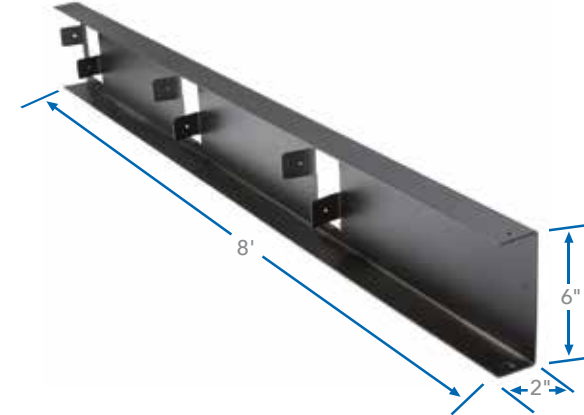

Blank Rim Joist

For use with or without fascia

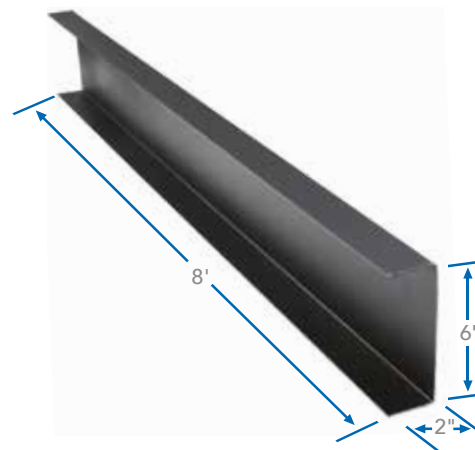

Curved Rim Joist

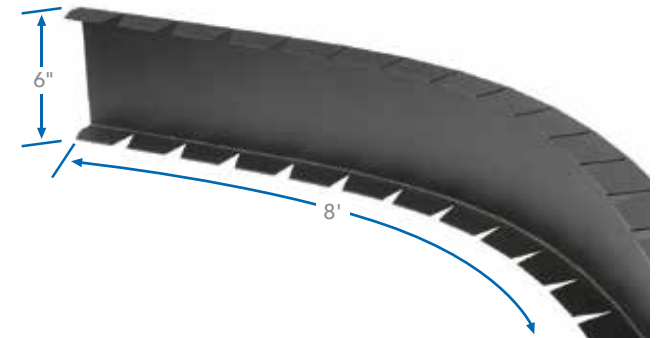

POST + POST BRACKETS

Post

Galvanized and powder coated with Black Sand. 3½" x 3½" x 10'

Post/Pier Bracket

Galvanized and powder coated with Black Sand.

Single Beam/Post Bracket

Galvanized and powder coated with Black Sand.

Double Beam/Post Bracket

Galvanized and powder coated with Black Sand.

Evolution's steel post and brackets provide the perfect solution to support your deck. The black powder coated posts look great on their own or can be customized with the trim of your choice.

Post

Used to support deck framing to concrete footings

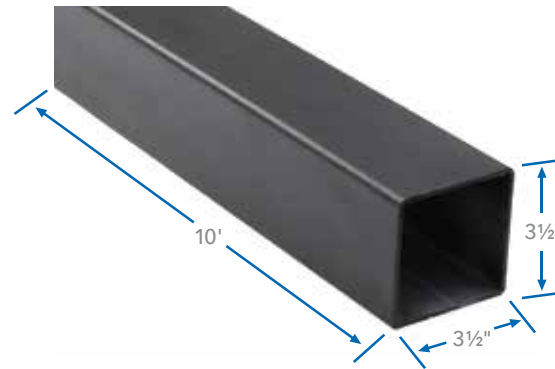

Single Beam/Post Bracket

Used to secure post to single beam

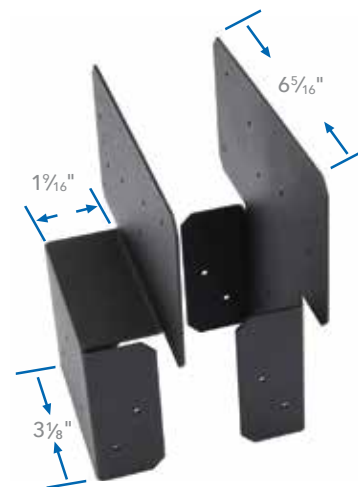

Post/Pier Bracket

Secures post to concrete landing or pier

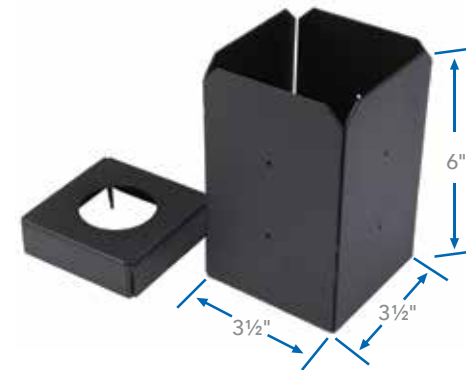

Double Beam/Post Bracket

Used to secure post to double beam

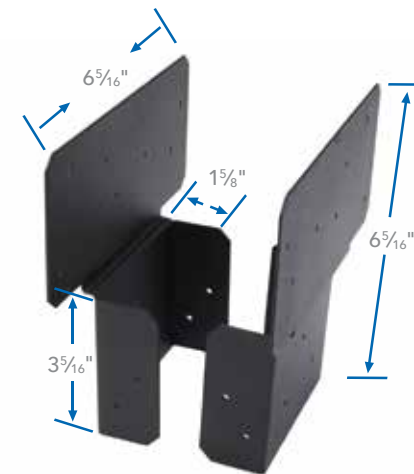

BRACKETS

F-10 Bracket

Galvanized and powder coated with Black Sand.

F-50 Bracket

Galvanized and powder coated with Black Sand.

Single Hanger Bracket

Galvanized and powder coated with Black Sand.

Double Hanger Bracket

Galvanized and powder coated with Black Sand.

F-10 Bracket

Used to secure joist to a drop beam when non-standard spacing is required and as a cap on the bottom of the S-Ledger



Single Hanger Bracket

Used to secure joist to flush beam applications

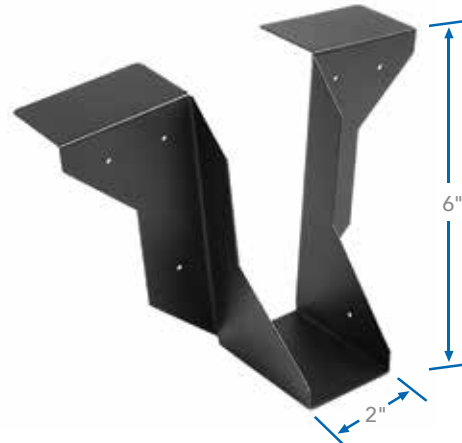

F-50 Bracket

Used with S-Ledger, joist, and blocking as well as many other applications



Double Hanger Bracket

Used to secure double joist or create a double (2"x6") carry beam



BRACKETS (CONTINUED)

Ledger Bracket

Galvanized and powder coated with Black Sand.

Ledger Bracket

Used with the S-Ledger and joist or fastened to a flush beam

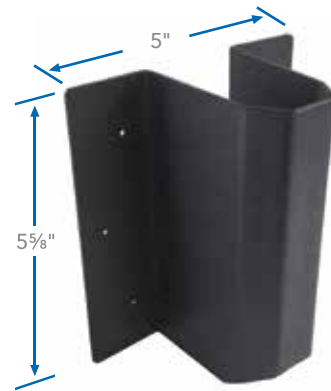

45° Bracket

Used with the Blank S-Ledger when joist extends at an angle to keep standard spacing

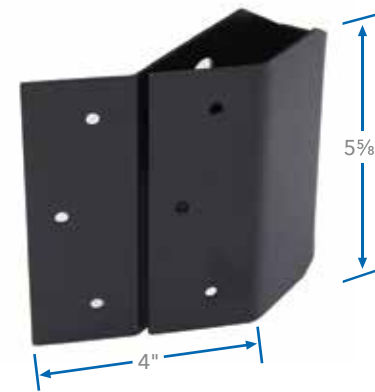

45° Bracket

Galvanized and powder coated with Black Sand.

Rim Joist Bracket

Inserts into joist at the end of the deck for attaching the Curved Rim Joist

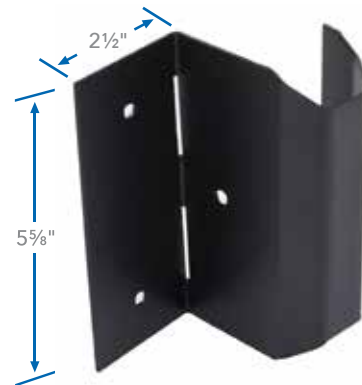

Rim Joist Bracket

Galvanized and powder coated with Black Sand.

BLOCKING + ACCESSORIES

Blocking

Galvanized and powder coated with Black Sand.
12" O.C. + 16" O.C.

Screw

Self-drilling metal screw
Head coated in black.

Blocking

Manufactured to match the same spacing as the S-Ledger for easy blocking of joist on a dropped beam

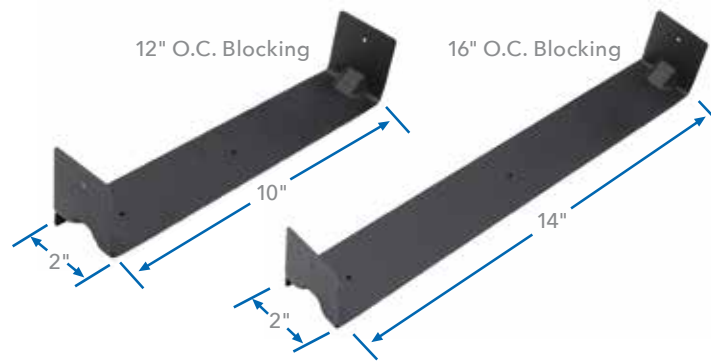

Screw

3/4" Black self-drilling metal screw



Strap

Manufactured to match the same spacing as the S-Ledger for easy mid-span blocking applications

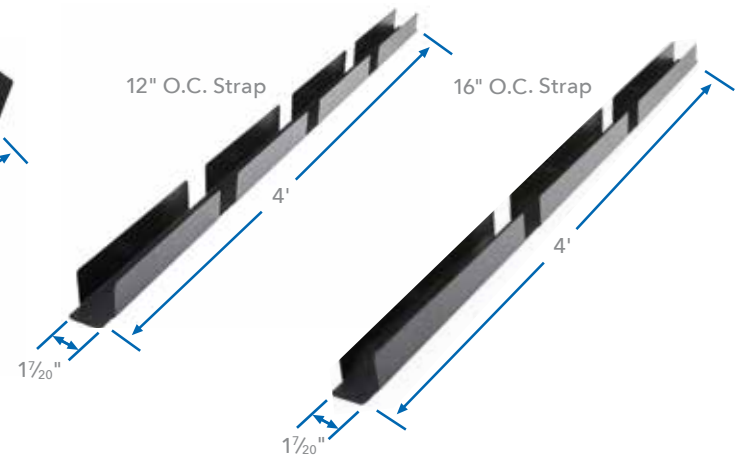



PRODUCT GUIDE

**EVOLUTION BY FORTRESS FRAMING HAS
COMPONENTS TO COVER VIRTUALLY ALL
NEEDS/APPLICATIONS**



JOIST - 16 GAUGE

ITEM #	DESCRIPTION	UPC #
181112161	FF-EVOLUTION-2X6 JOIST-12'-16GA-PC	811397030170
181114161	FF-EVOLUTION-2X6 JOIST-14'-16GA-PC	811397030163
181116161	FF-EVOLUTION-2X6 JOIST-16'-16GA-PC	811397030156
181118161	FF-EVOLUTION-2X6 JOIST-18'-16GA-PC	811397030149
181120161	FF-EVOLUTION-2X6 JOIST-20'-16GA-PC	811397030132



JOIST - 18 GAUGE

ITEM #	DESCRIPTION	UPC #
181112180	FF-EVOLUTION-2X6 JOIST-12'-18GA	811397030224
181114180	FF-EVOLUTION-2X6 JOIST-14'-18GA	811397030217
181116180	FF-EVOLUTION-2X6 JOIST-16'-18GA	811397030200
181118180	FF-EVOLUTION-2X6 JOIST-18'-18GA	811397030194
181120180	FF-EVOLUTION-2X6 JOIST-20'-18GA	811397030187

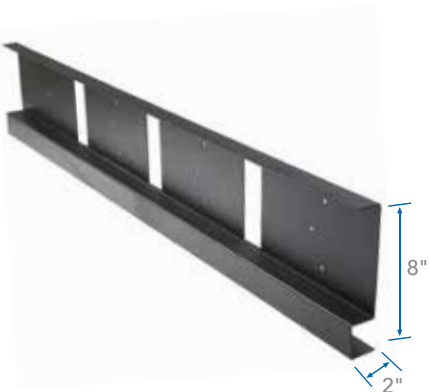

S-LEDGER

ITEM #	DESCRIPTION	UPC #
182012141	FF-EVOLUTION-S-LEDGER-12'	811397030293
182020141	FF-EVOLUTION-S-LEDGER-20'	811397030309
182112141	FF-EVOLUTION-12OC-S-LEDGER-12'	811397030316
182120141	FF-EVOLUTION-12OC-S-LEDGER-20'	811397030354
182212141	FF-EVOLUTION-16OC-S-LEDGER-12'	811397030330
182220141	FF-EVOLUTION-16OC-S-LEDGER-20'	811397030347



BEAM

ITEM #	DESCRIPTION	UPC #
184108161	FF-EVOLUTION-BEAM 2X11-8'	811397030361
184112161	FF-EVOLUTION-BEAM 2X11-12'	811397030378
184116161	FF-EVOLUTION-BEAM 2X11-16'	811397030385
184120161	FF-EVOLUTION-BEAM 2X11-20'	811397030392

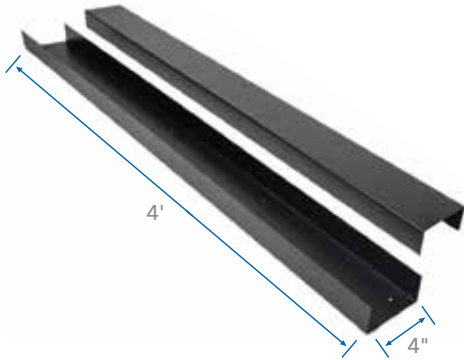

DOUBLE BEAM TRACK

ITEM #	DESCRIPTION	UPC #
184204161	FF-EVOLUTION-DBL BEAM TRACK-4' (2 PACK)	811397030408

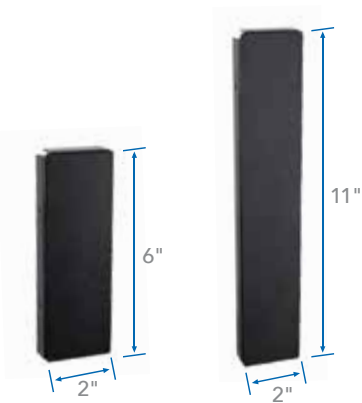

CAPS

ITEM #	DESCRIPTION	UPC #
183062001	FF-EVOLUTION-JOIST CAP	811397030262
183112001	FF-EVOLUTION-BEAM CAP	811397030279

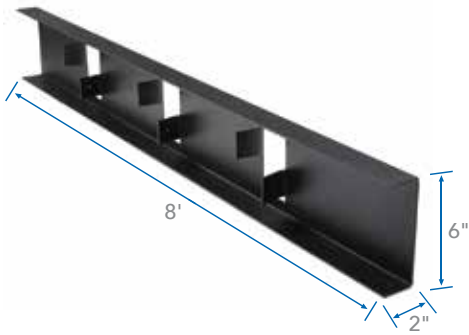

RIM JOIST

ITEM #	DESCRIPTION	UPC #
185108141	FF-EVOLUTION-12OC U-RIM JOIST-2X6-8'	811397030422
185208141	FF-EVOLUTION-16OC U-RIM JOIST-2X6-8'	811397030439

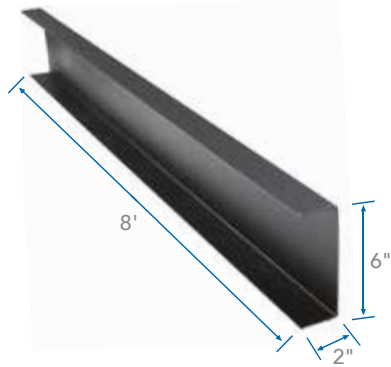

RIM JOIST - BLANK

ITEM #	DESCRIPTION	UPC #
185008141	FF-EVOLUTION-U-RIM JOIST-2X6-8'	811397030415

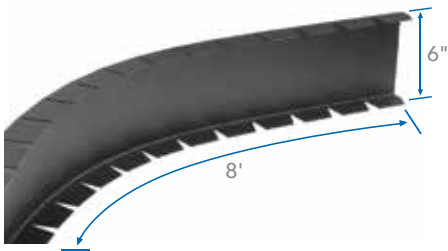

RIM JOIST - CURVED

ITEM #	DESCRIPTION	UPC #
185308161	FF-EVOLUTION-CURVE-RIM JOIST-2X6-8'	811397030446

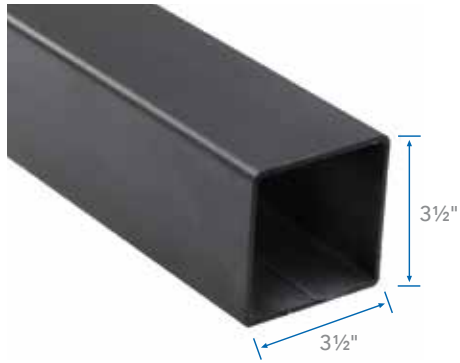

POST

ITEM #	DESCRIPTION	UPC #
186110111	FF-EVOLUTION-POST 3.5X3.5-10'	811397030248

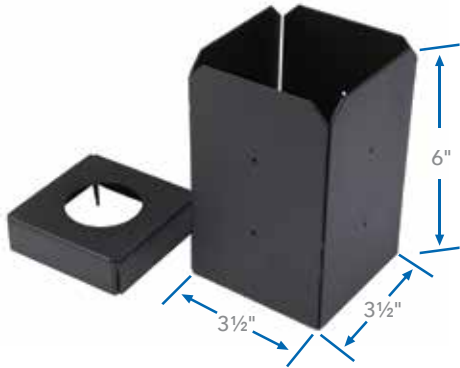

POST TO PIER BRACKET

ITEM #	DESCRIPTION	UPC #
183351601	FF-EVOLUTION-3.5" POST/PIER BRACKET	811397030286

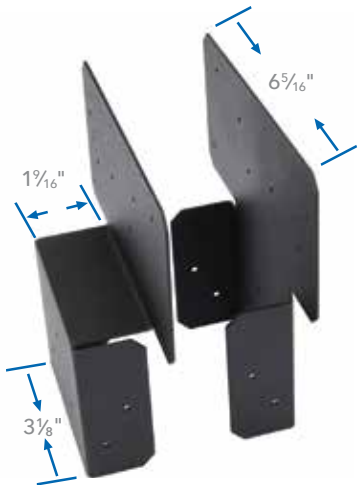

SINGLE BEAM TO POST BRACKET

ITEM #	DESCRIPTION	UPC #
183161601	FF-EVOLUTION-SNGL BEAM/POST BRACKET	811397030057

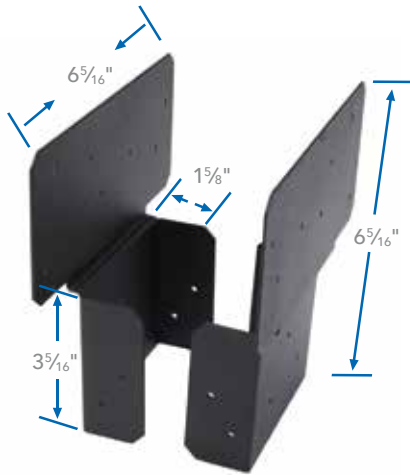

DOUBLE BEAM TO POST BRACKET

ITEM #	DESCRIPTION	UPC #
183261601	FF-EVOLUTION-DBL BEAM/POST BRACKET	811397030040

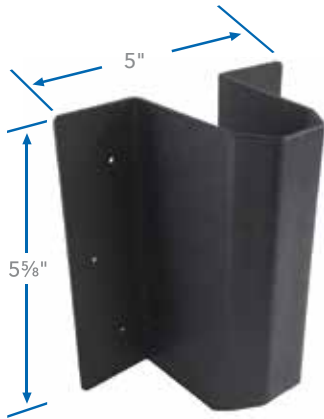

LEDGER BRACKET

ITEM #	DESCRIPTION	UPC #
183011401	FF-EVOLUTION-LEDGER BRACKET	811397030125



F10 BRACKET

ITEM #	DESCRIPTION	UPC #
183041601	FF-EVOLUTION-F10 BRACKET (BOX 10)	811397030453

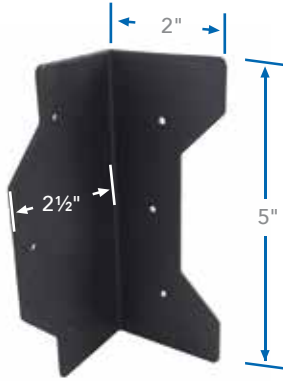

F50 BRACKET

ITEM #	DESCRIPTION	UPC #
183021601	FF-EVOLUTION-F50 BRACKET	811397030118

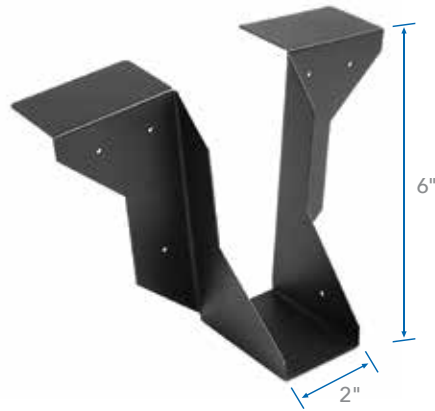

SINGLE HANGER BRACKET

ITEM #	DESCRIPTION	UPC #
183102001	FF-EVOLUTION-SNGL HANGER BRACKET	811397030071



DOUBLE HANGER BRACKET

ITEM #	DESCRIPTION	UPC #
183202001	FF-EVOLUTION-DBL HANGER BRACKET	811397030064

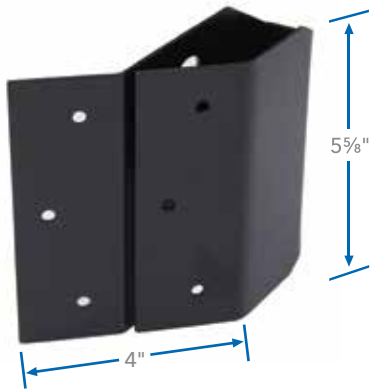

45° BRACKET

ITEM #	DESCRIPTION	UPC #
183451401	FF-EVOLUTION-45 DEG BRACKET	811397030101

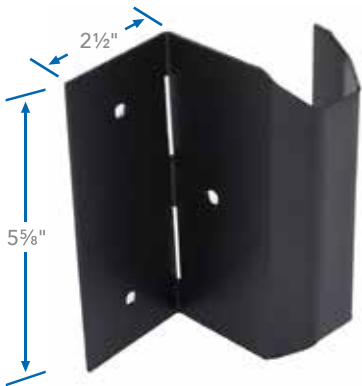

RIM JOIST BRACKET

ITEM #	DESCRIPTION	UPC #
183031801	FF-EVOLUTION-RIM JOIST BRACKET	811397030095

BLOCKING

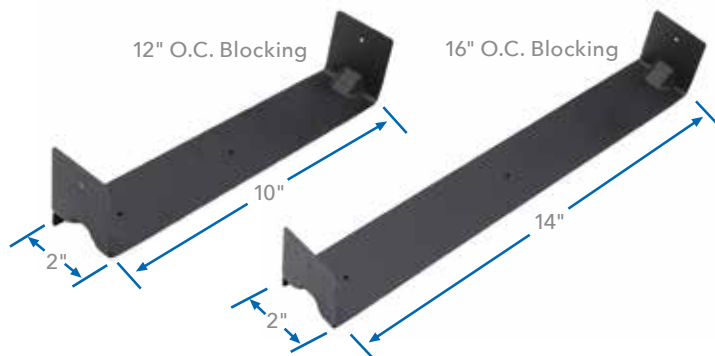

ITEM #	DESCRIPTION	UPC #
188122001	FF-EVOLUTION-12OC BLOCKING	811397030033
188162001	FF-EVOLUTION-16OC BLOCKING	811397030026

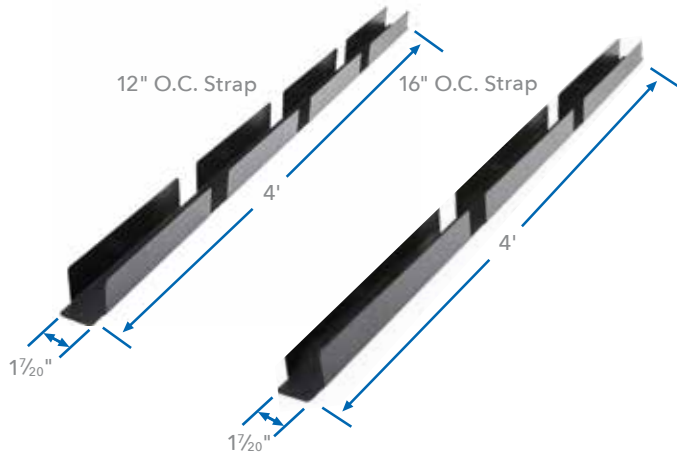

STRAP

ITEM #	DESCRIPTION	UPC #
187104201	FF-EVOLUTION-12OC STRAP	811397030002
187204201	FF-EVOLUTION-16OC STRAP	811397030019

SELF-DRILLING SCREW



ITEM #	DESCRIPTION	UPC #
183990341	FF-EVOLUTION 3/4" BLACK SELF-DRILLING SCREW (BAG 250)	811397030255

BLACK SAND TOUCH UP PAINT



ITEM #	DESCRIPTION	UPC #
183280601	FF-BLACK SAND (BKSND) AEROSOL TOUCH UP PAINT	811397030736



PROTECT YOUR PROJECTS WITH A SOLID FOUNDATION

When compared with wood, Evolution Steel Deck Framing is surprisingly affordable and dependably durable, a win for both contractors and customers. Visit fortressframing.com now to find a distributor in your area.



ELIMINATE TIME AND HEADACHES

THE EVOLUTION STEEL STAIR SYSTEM IS A COMPLETE, ENGINEERED STAIR SOLUTION FOR ANY APPLICATION.

EVOLUTION STEEL STAIR SYSTEM

The stair components and brackets work with the Evolution Joist and Beams to provide a quick, easy assembly, dramatically decreasing installation time! The Black Sand powder coat delivers an aesthetically pleasing modern look on its own or use with fascia/trim for a more traditional look.

PARTS SHOWN

1. Beam (or deck/structure)
2. Stair Strap
3. Stringer Evolution 2"x6" Joist **or** 2"x11" Beam
4. Stair Stringer Anchor Bracket
5. Preset 7"/11" Stair Bracket
6. 48" Stair Tray



Patent Pending

PARTS NOT SHOWN... but available to cover virtually all needs/applications.

- Preset 7 $\frac{3}{4}$ "/11" Stair Bracket
- Adjustable Stair Bracket

COMPONENTS

48" Stair Tray

The Evolution Stair Tray allows quick and easy installation without all the stringers and hassle. The lateral supports are spaced to work with any kind of deck board and provides blocking for surface mounted posts.

Stair Stringer Anchor Bracket

The Evolution Stair Stringer Anchor Bracket is reversible, allowing a secure, connection from the stringer to the footing, slab or pier under the last tread. Providing an aesthetically seamless transition from the stairs.

Stair Strap

The Evolution Stair Strap allows flexibility when connecting the stairs to the deck, landing or structure, while securely holding the stringers in place.

The Evolution Stair Components have been designed and engineered to eliminate the need for excessive stringers and work with any composite, PVC and tropical hardwood deck boards.

48" Stair Tray

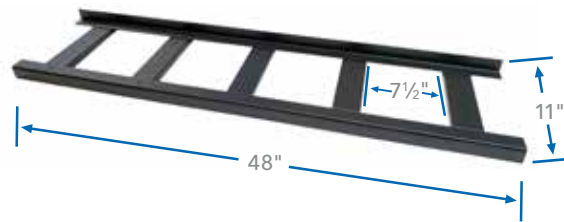

Stair Stringer Anchor Bracket

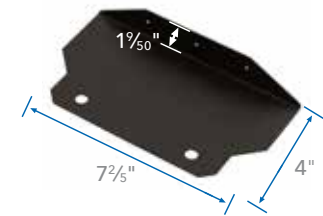

Stair Strap

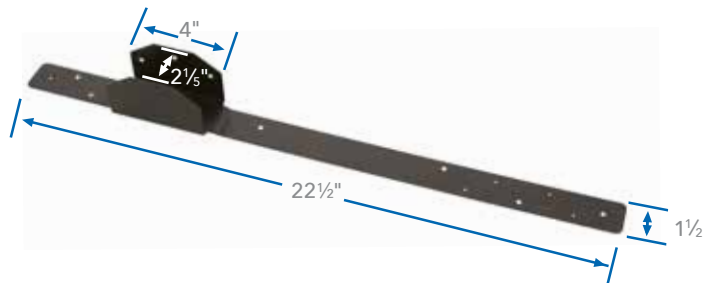

BRACKETS

Preset 7"/11" Stair Bracket

The Evolution Preset 7"/11" Stair Bracket is engineered to slide over the top of an Evolution Joist and provide a perfect 7" rise and 11" run for the stringer. These brackets align directly with one another resulting in a rapid, worry-free stringer installation.

Preset 7¾"/11" Stair Bracket

The Evolution Preset 7¾"/11" Stair Bracket is engineered to slide over the top of an Evolution Joist and provide a perfect 7¾" rise and 11" run for the stringer. These brackets align directly with one another resulting in a rapid, worry-free stringer installation.

Adjustable Stair Bracket

The Evolution Adjustable Stair Bracket allows you to quickly and easily customize the stair's rise and run using the two provided set pins. Simply place the set pins in the desired holes and slide the stair brackets over an Evolution Joist to complete the stringer installation.

Evolution Stair Brackets have been designed to accommodate virtually any rise/run options. The stair brackets attach directly to the top of the Evolution Joist or Beams for quick and easy installation without the irritation of traditional stair applications.

Preset 7"/11" Stair Bracket

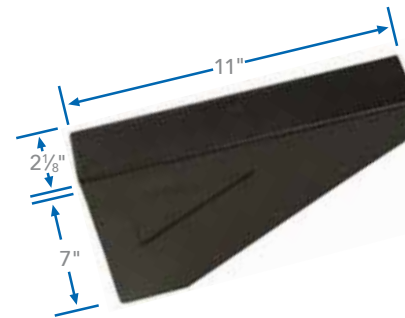

Preset 7¾"/11" Stair Bracket

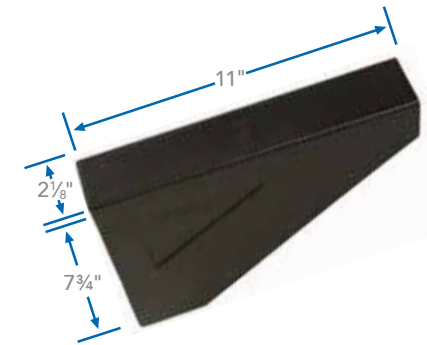

Adjustable Stair Bracket

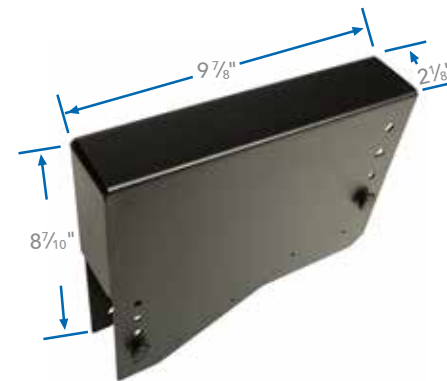



PRODUCT GUIDE

**EVOLUTION STAIR SYSTEM BY FORTRESS
FRAMING HAS COMPONENTS TO COVER
VIRTUALLY ALL NEEDS/APPLICATIONS**

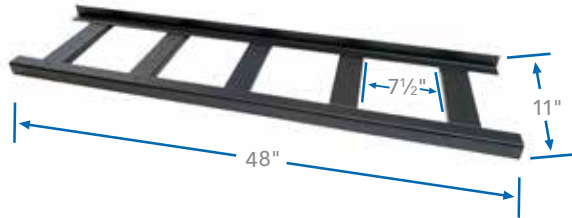

48" STAIR TRAY

ITEM #	DESCRIPTION	UPC #
189348161	FF-EVOLUTION-48" STAIR TRAY	811397030712

STAIR STRINGER ANCHOR BRACKET

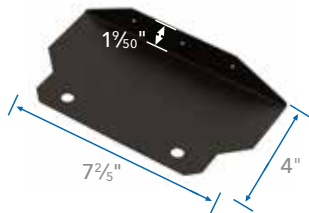

ITEM #	DESCRIPTION	UPC #
189100161	FF-EVOLUTION-STAIR ANCHOR BRACKET	811397030682

STAIR STRAP

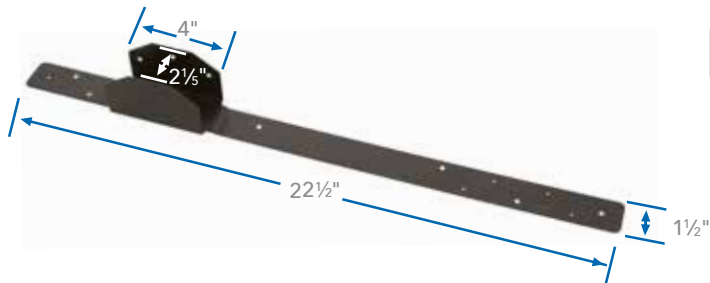

ITEM #	DESCRIPTION	UPC #
189223181	FF-EVOLUTION-STAIR STRAP	811397030675

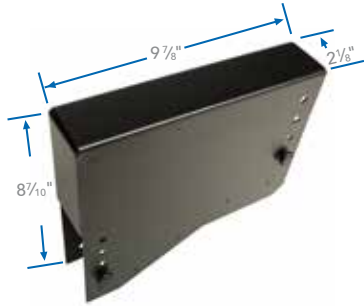

ADJUSTABLE STAIR BRACKET

ITEM #	DESCRIPTION	UPC #
189199141	FF-EVOLUTION-ADJUSTABLE STAIR BRACKET	811397030705

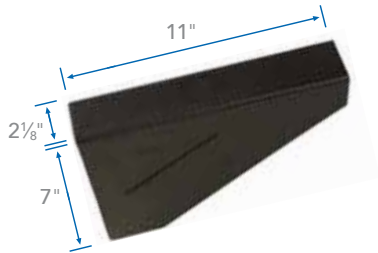

7"/11" STAIR BRACKET

ITEM #	DESCRIPTION	UPC #
189107161	FF-EVOLUTION-7"/11" STAIR BRACKET	811397030651

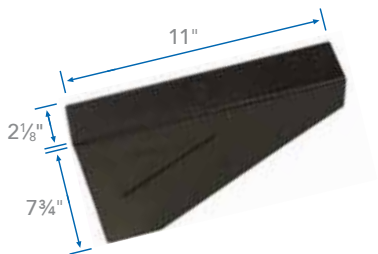

7 3/4"/11" STAIR BRACKET

ITEM #	DESCRIPTION	UPC #
189134161	FF-EVOLUTION-7 3/4"/11" STAIR BRACKET	811397030668

STAIR CALCULATOR

Building with the Adjustable Stair Bracket is easy when you use the online custom stair calculator. Simply choose your stair configuration, enter a few parameters, and the calculator will show you how to build your stringer!

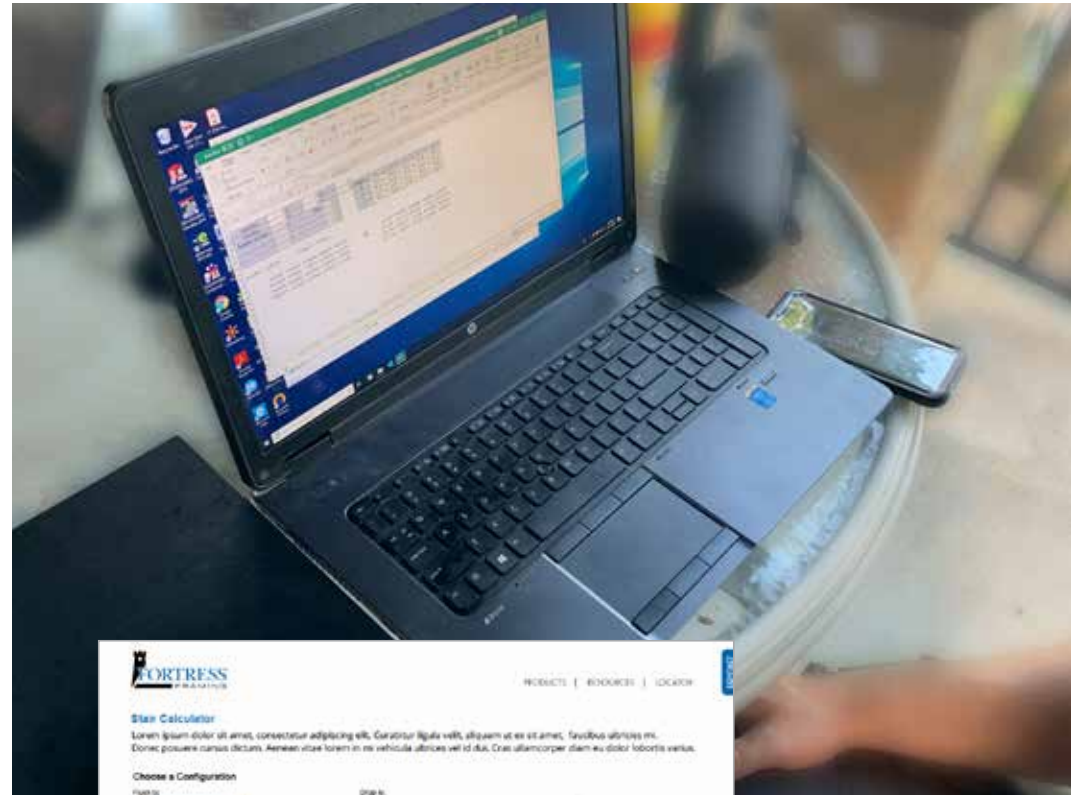

FORTRESS
FRAMING

PROJECTS | RESOURCES | LOCATOR

Stair Calculator

Lorem ipsum dolor sit amet, consectetur adipiscing elit. Curabitur ligula velit, aliquam at et et amet, fructibus ultrices mi. Donec posuere cursus dictum. Aenean vitae lorem in mi vehicula ultrices vel id dui. Cras ultramcorper diam eu dolor lobortis varius.

Choose a Configuration

Click to: **Stair** | Landing | Landing | Stair | Landing

Rise and Tread

Rise: 8 | Tread: 11

Steps

None (8 step options are available given the rise and tread depth selected.)
18 Steps - 18 (19)2 Run

Results

Rise: 7.27' | Total Run: 180 (19)2
Uniform Step: 6.77' | Stringer Length: 161 (14)2
Angle: 38.45'

FORTRESS
FRAMING

Home | Products | Info/About | Warranty | Contact | Submit Project Request

Fortress Framing is a subsidiary of Fortman Building Products.
200 Fortman Road | Fortman Blvd | Fortman Blvd | Fortman Blvd | 00000 Building Products
© 2018 Fortress Framing. Fortress is a registered trademark.

THE TOTAL FORTRESS SOLUTION

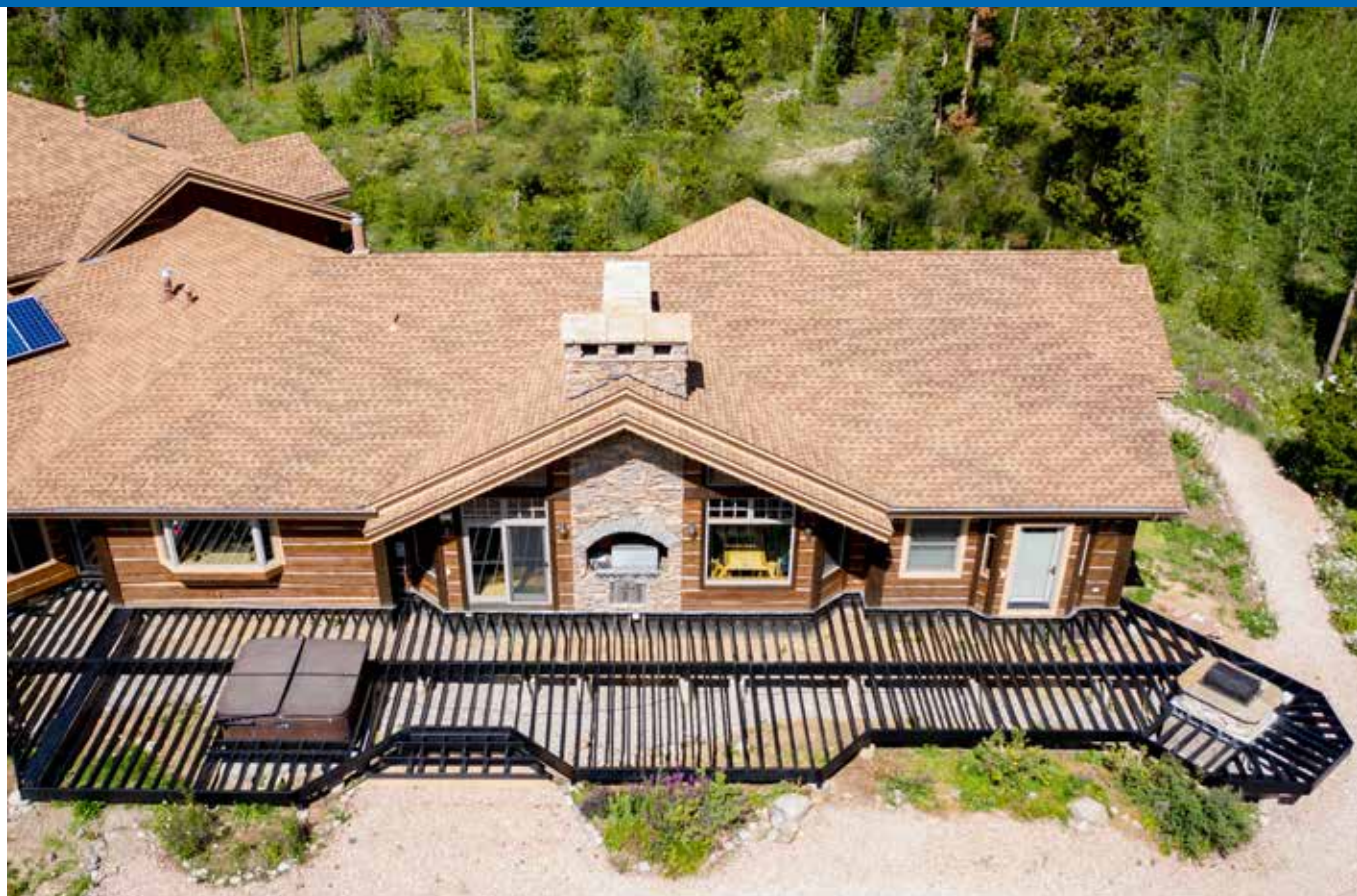

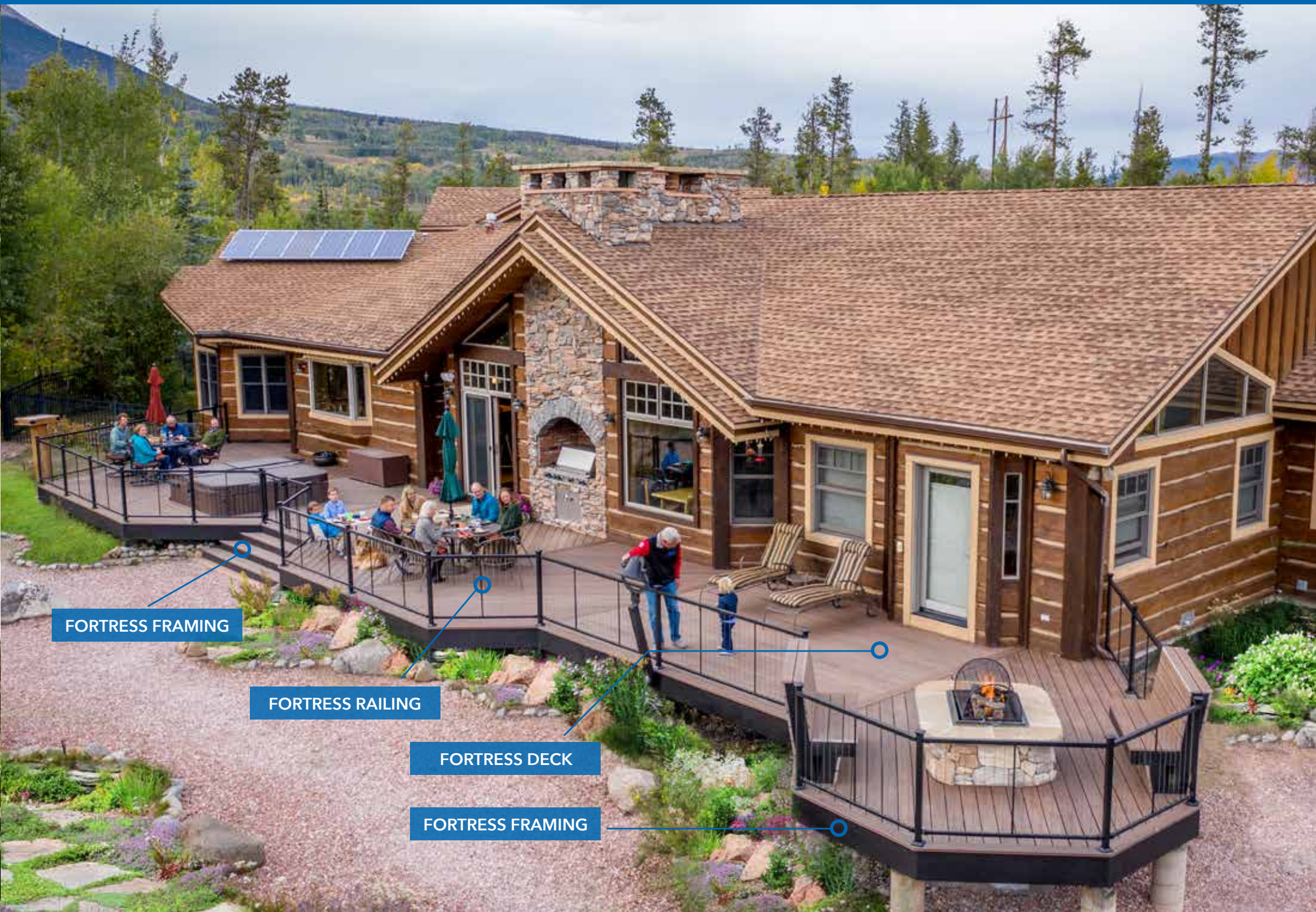

FORTRESS FRAMING

FORTRESS RAILING

FORTRESS DECK

FORTRESS FRAMING

FORTRESS PREFERRED PROGRAM

JOIN NOW

Put the power of the Fortress brand behind you when you become a member of the Fortress Preferred Program. By promoting and installing Fortress Building Products, you can offer your customers an extended 5 year labor coverage while earning rebates. As a valued and trusted Fortress partner you'll be able to provide a quality customer experience through every step of the design/build process.

LET'S DO THIS!



5 Year Limited Labor Coverage

As a Fortress Preferred Partner, you can deliver an even greater peace of mind to your customers with five years of labor coverage. If any Fortress product fails to perform in accordance with its original warranty, adequate replacement costs will be covered.



**BECOME A
FORTRESS
PREFERRED
MEMBER
TODAY**



BENEFITS & BEYOND

- Instant enrollment in the Fortress Preferred Rebate Program
- Ability to offer a 5-year Labor Coverage
- Listed as Fortress Preferred on the website
- Sales and Marketing Tools, such as samples, literature and branded merchandise
- Priority lead referral
- Priority support from the Fortress Sales and Customer Care Team

ON YOUR END

- Valid contractor license
- General liability insurance
- Continued promotion of Fortress Building Products to leads acquired from the Fortress Preferred Program membership
- Completion of any required ongoing continuing education
- Completion and submittal of all required registration information





FortressBP.com

EVOLUTION™
STEEL DECK FRAMING